

UTC HE8550 PNP EPITAXIAL SILIC ON TRANSISTOR

LOW VOLTAGE HIGH CURRENT SMALL SIGNAL PNP TRANSISTOR

DESCRIPTION

The UTC HE8550 is a low voltage high current small signal PNP transistor, designed for Class B push-pull 2W audio amplifier for portable radio and general purpose applications.

FEATURES

- *Collector current up to 1.5A
- *Collector-Emitter voltage up to 25 V
- *Complimentary to UTC HE8050

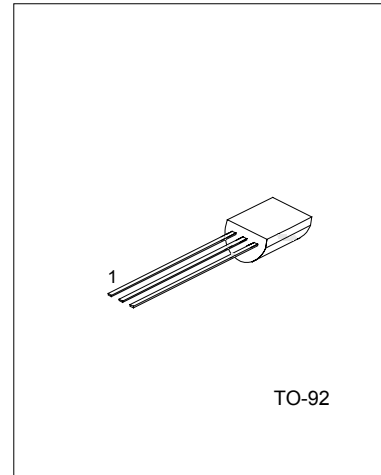

TO-92

1:EMITTER 2:COLLECTOR 3:BASE

ABSOLUTE MAXIMUM RATINGS (Ta=25°C ,unless otherwise specified)

PARAMETER	SYMBOL	VALUE	UNIT
Collector-Base Voltage	V _{CB0}	-40	V
Collector-Emitter Voltage	V _{CEO}	-25	V
Emitter-Base Voltage	V _{EB0}	-6	V
Collector Dissipation(Ta=25°C)	P _c	1	W
Collector Current	I _c	-1.5	A
Junction Temperature	T _j	150	°C
Storage Temperature	T _{STG}	-65 ~ +150	°C

ELECTRICAL CHARACTERISTICS(T_j=25°C,unless otherwise specified)

PARAMETER	SYMBOL	TEST CONDITIONS	MIN	TYP	MAX	UNIT
Collector-Base Breakdown Voltage	BV _{CB0}	I _c =-100μA, I _E =0	-40			V
Collector-Emitter Breakdown Voltage	BV _{CEO}	I _c =-2mA, I _B =0	-25			V
Emitter-Base Breakdown Voltage	BV _{EB0}	I _E =-100μA, I _c =0	-6			V
Collector Cut-Off Current	I _{CB0}	V _{CB} =-35V, I _E =0			-100	nA
Emitter Cut-Off Current	I _{EB0}	V _{EB} =-6V, I _c =0			-100	nA
DC Current Gain(note)	h _{FE1}	V _{CE} =-1V, I _c =-5mA	45	170		
	h _{FE2}	V _{CE} =-1V, I _c =-100mA	85	160	500	
	h _{FE3}	V _{CE} =-1V, I _c =-800mA	40	80		
Collector-Emitter Saturation Voltage	V _{CE(sat)}	I _c =-800mA, I _B =-80mA		-0.28	-0.5	V
Base-Emitter Saturation Voltage	V _{BE(sat)}	I _c =-800mA, I _B =-80mA		-0.98	-1.2	V
Base-Emitter Voltage	V _{BE}	V _{CE} =-1V, I _c =-10mA		-0.66	-1.0	V
Current Gain Bandwidth Product	f _T	V _{CE} =-10V, I _c =-50mA	100	190		MHz
Output Capacitance	C _{ob}	V _{CB} =-10V, I _E =0 f=1MHz		9.0		pF

UTC HE8550 PNP EPITAXIAL SILIC ON TRANSISTOR

CLASSIFICATION OF hFE

RANK	C	D	E
RANGE	120-200	160-300	250-500

TYPICAL PERFORMANCE CHARACTERISTICS

Fig.1 Static characteristics

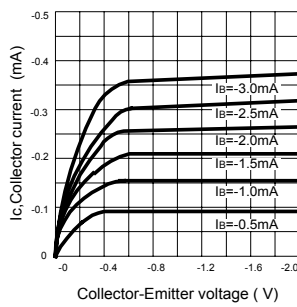

Fig.2 DC current Gain

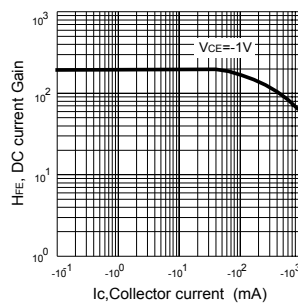

Fig.3 Base-Emitter on Voltage

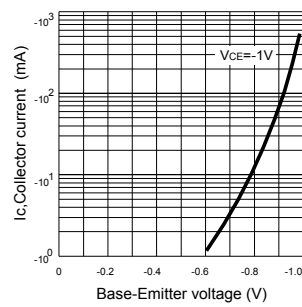

Fig.4 Saturation voltage

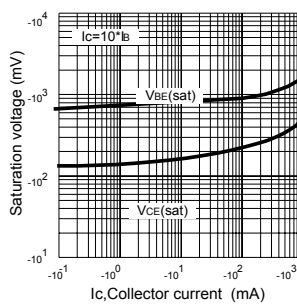

Fig.5 Current gain-bandwidth product

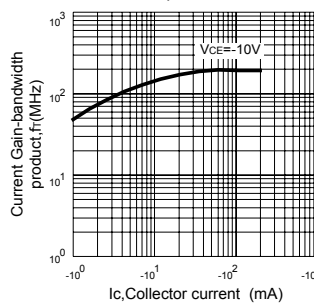

Fig.6 Collector output Capacitance

